



# *FIBER TO THE CURB*

## *POWERING, PROTECTION, & GROUNDING*

**Bruce Fountain**

**National Standards & Processes**



# *FTTC Deployment Scheme*

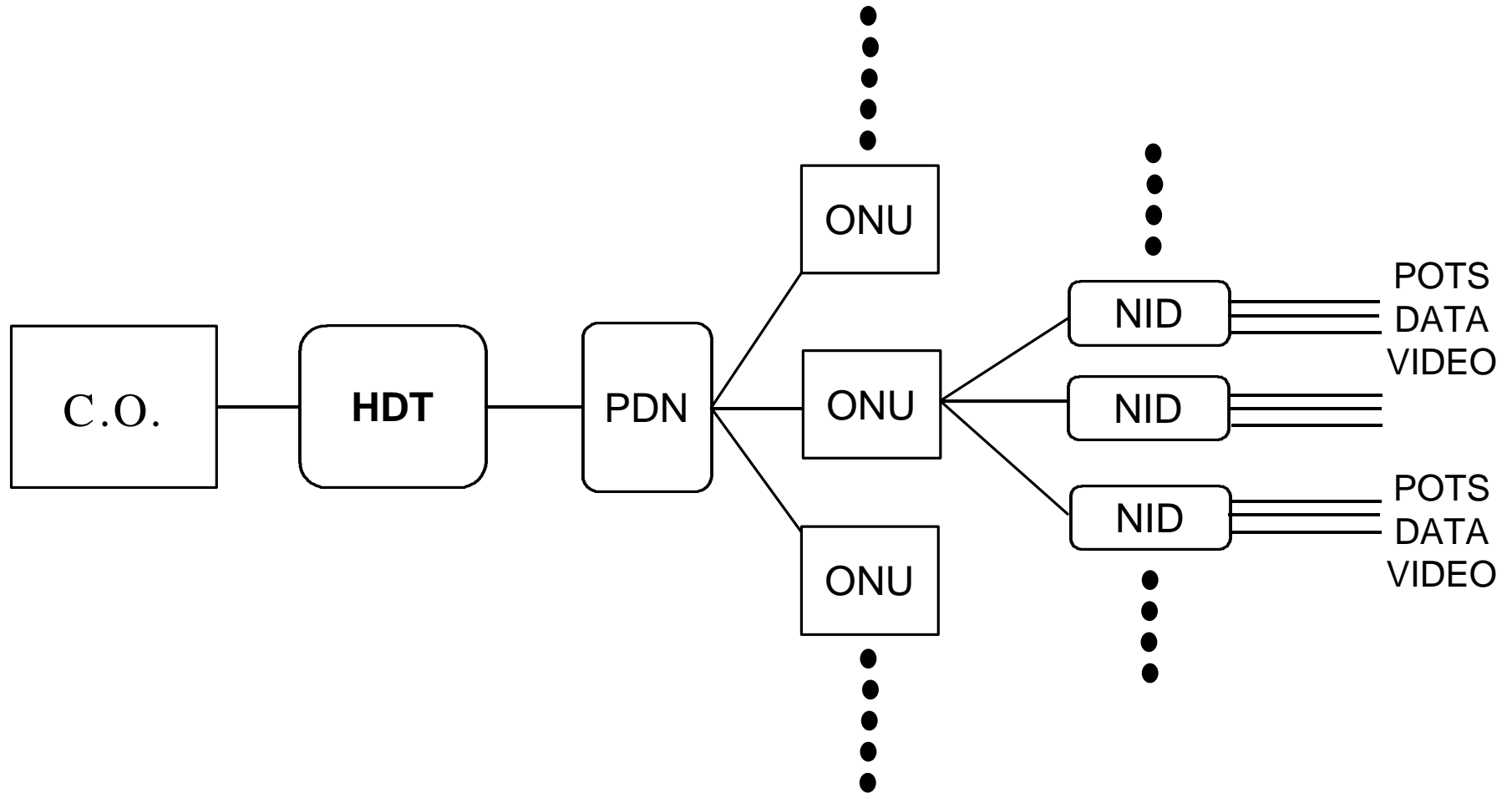



## *Purpose*

**Discussion of recommended protection measures for the Host Digital Terminal (HDT), Optical Network Units (ONU), and Network Interface Protection deployed into the local loop (Outside Plant) telephone network.**

- 1. Protection Objectives**
- 2. Powering Scheme**
- 3. Cable Shielding & Power Pair Protection**
- 4. ONU Grounding, Bonding, & VF Protection**
- 5. High Speed Data Protection**



**Sprint**<sup>®</sup>





## *Network Protection Objectives*

- Provide the required / mandated protection for the HDT, ONU & NID.
- Personnel Safety
- Network Operation and Equipment Reliability





## Centralized Powering Scheme

- ◆ HDT: Bulk -48VDC and Lead Acid Storage Battery, with DC-DC conversion to -130VDC. Power is carried to the ONU over Copper Twisted Pair.
- ◆ Power Supply (at HDT) limits power to 100VA for each ONU with Current Limiter's (Fold Back characteristic & auto restart). These generally limit at 750mA.
- ◆ The ONU has DC-DC conversion and typically consumes 20W-30W of power.
- ◆ The ONU is fed with a Hybrid or Composite type cable consisting of the Copper Pair and the Optical Fiber. The cable sheath uses a core wrap and a corrugated copper/aluminum shield with an insulating jacket.





## Cable Shielding & Bonding

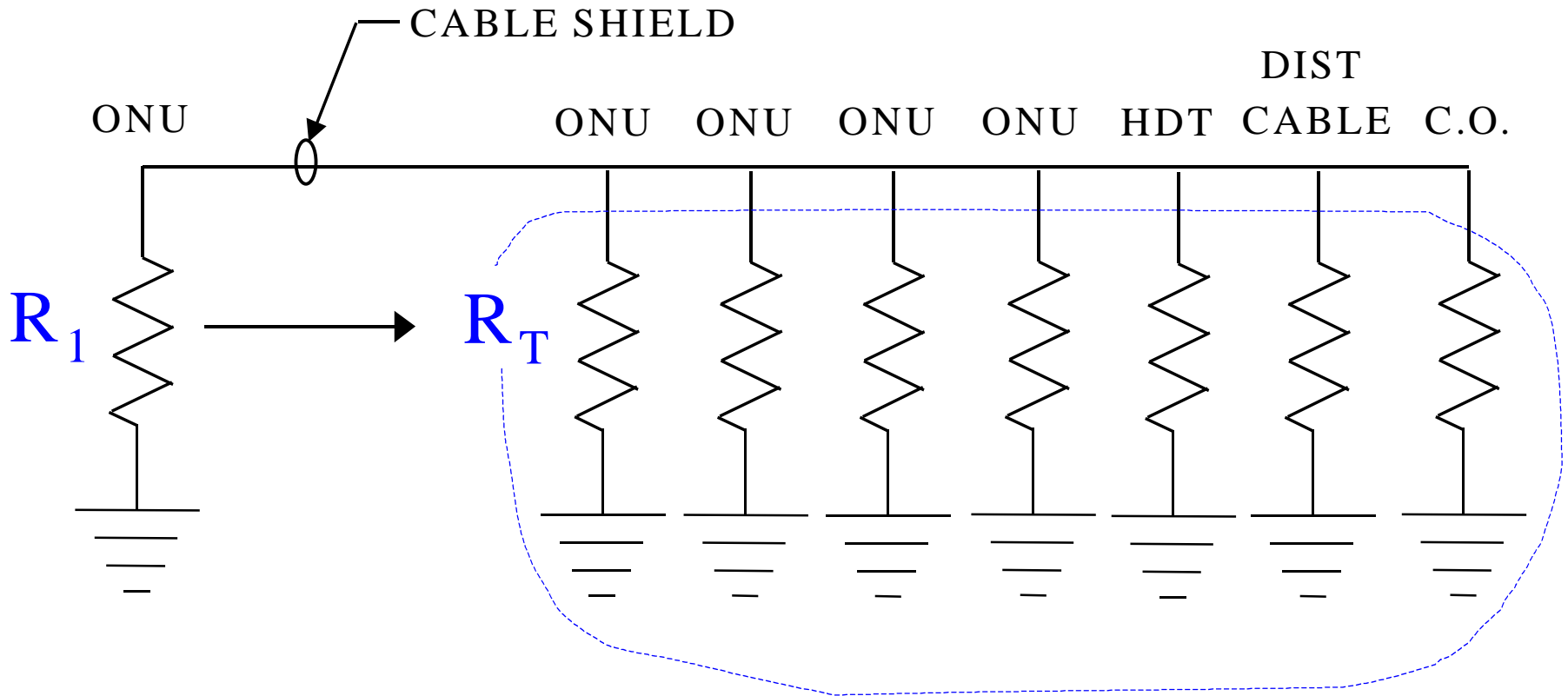

RESISTANCE OF  $R_1$  DUE TO CABLE SHIELD  
BONDING / GROUNDING AND HDT / C.O. GROUND





## Powering Pair Protection

- ◆ The -130VDC powering pair(s) are protected at both the HDT and the ONU with an over voltage protector.
- ◆ The Protector at the HDT can be a standard “300V” protector.
- ◆ The more difficult issue is protecting the powering pair(s) at the ONU. The protector must coordinate with the HDT Power Supply. Today we are recommending the Gas Tube protector (265V-300V) designed specifically for high extinguishing current (DC Holdover). [SSOV protectors have poor current handling characteristics and lock up in holdover at much lower currents].
- ◆ At the ONU the Powering Pair(s) are terminated at one position on the punch down termination block. A single AWG #24 gauge stub pair serves as a Fusible Link and terminates on a single Gas Tube protector.





## ONU Grounding, Bonding, & VF Protection

- ◆ The ONU contains a ground bus bar provisioned and bolted directly to the metallic frame of the ONU closure. Cable shields, grounding conductors and bonding conductors are terminated on the ground bus bar.
- ◆ Bond the ONU enclosure to the MGN when practical (10 foot rule). Bond and ground the ONU enclosure using a buried 10 foot (or 8') 5/8" copper clad steel ground rod.
- ◆ The cable shield is brought into the ONU enclosure and bonded to the ONU ground bar. (bonds made with AWG #6 copper wire)
- ◆ At the ONU the VF pairs leaving the ONU will be protected with the same protectors (Gas Tubes) used on the powering pairs. At present we are not shielding the customer service drop.





## NID & High Speed Data Protection (Discussion)

- ◆ Does the CPE Network Interface Card (NIC) meet a specific voltage and energy withstand requirement?
- ◆ Does the CPE Workstation NIC or Broadband Services NIU require special or secondary protection by the telco?
- ◆ Is secondary low voltage protection brought out to the NID?
- ◆ If secondary or special protection IS REQUIRED by telco:
  - A combination of a standard 300V protector coupled by resistive voltage drop with a low voltage MOV insuring low voltage firing and higher energy protection?
  - A hybrid protector with good data handling characteristics, but normal (300V) firing voltage characteristics?
  - Recommendation to customer for protector at workstation?





## FTTC Powering Voltages (discussion)

- ◆ Is  $\pm 130\text{VDC}$  (260V) acceptable for powering FITL as power requirements increase? Is this being done?



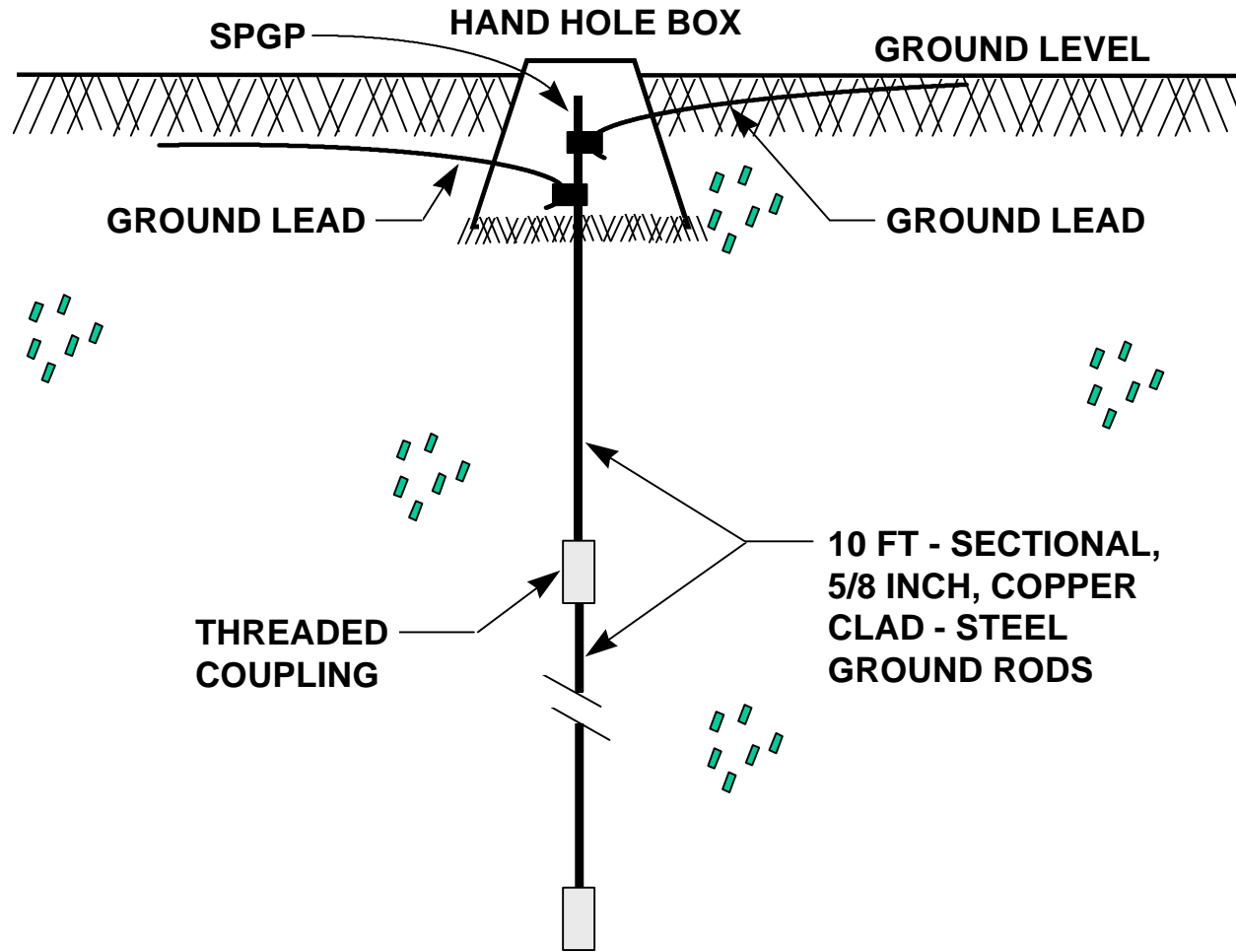

MADE GROUND ELECTRODE - METHOD #1  
FIGURE C





## RADIAL - 6 BRANCH STAR CONFIGURATION

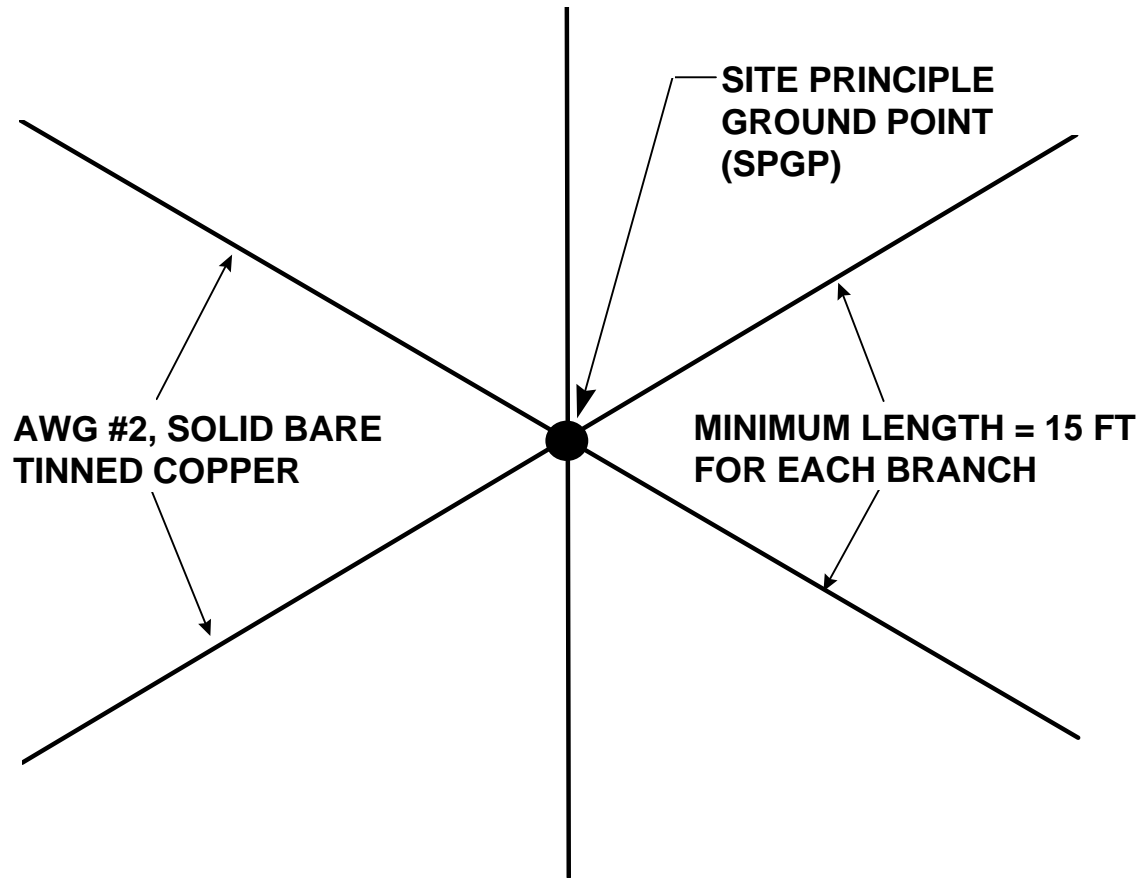

MADE GROUND ELECTRODE - METHOD #2  
FIGURE D



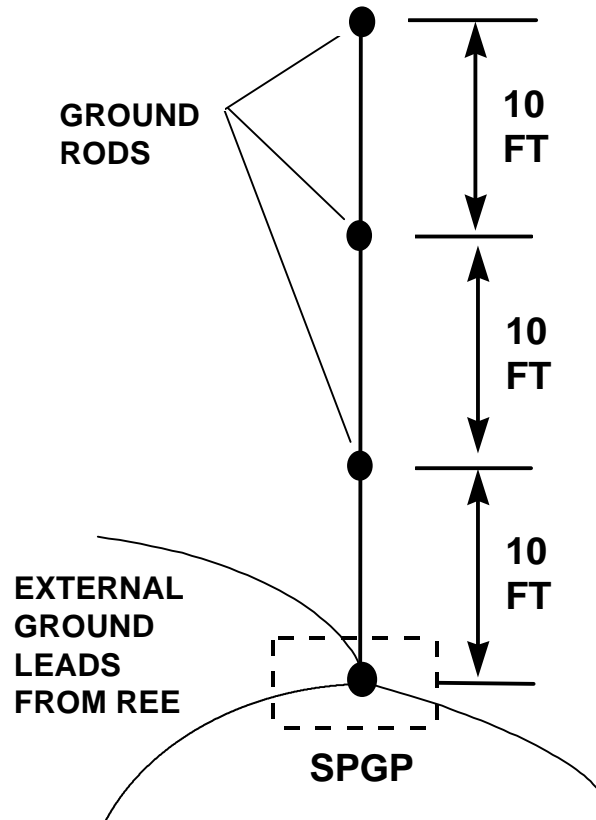

- 1) AWG #2, SOLID BARE TINNED COPPER
- 2) MINIMUM OF THREE - 10 FT SECTIONAL DRIVEN RODS
- 3) ROD SPACING IS EQUAL TO OR GREATER THAN ROD LENGTH
- 4) EXOTHERMIC WELD CONNECTIONS

MADE GROUND ELECTRODE - METHOD #3  
FIGURE E

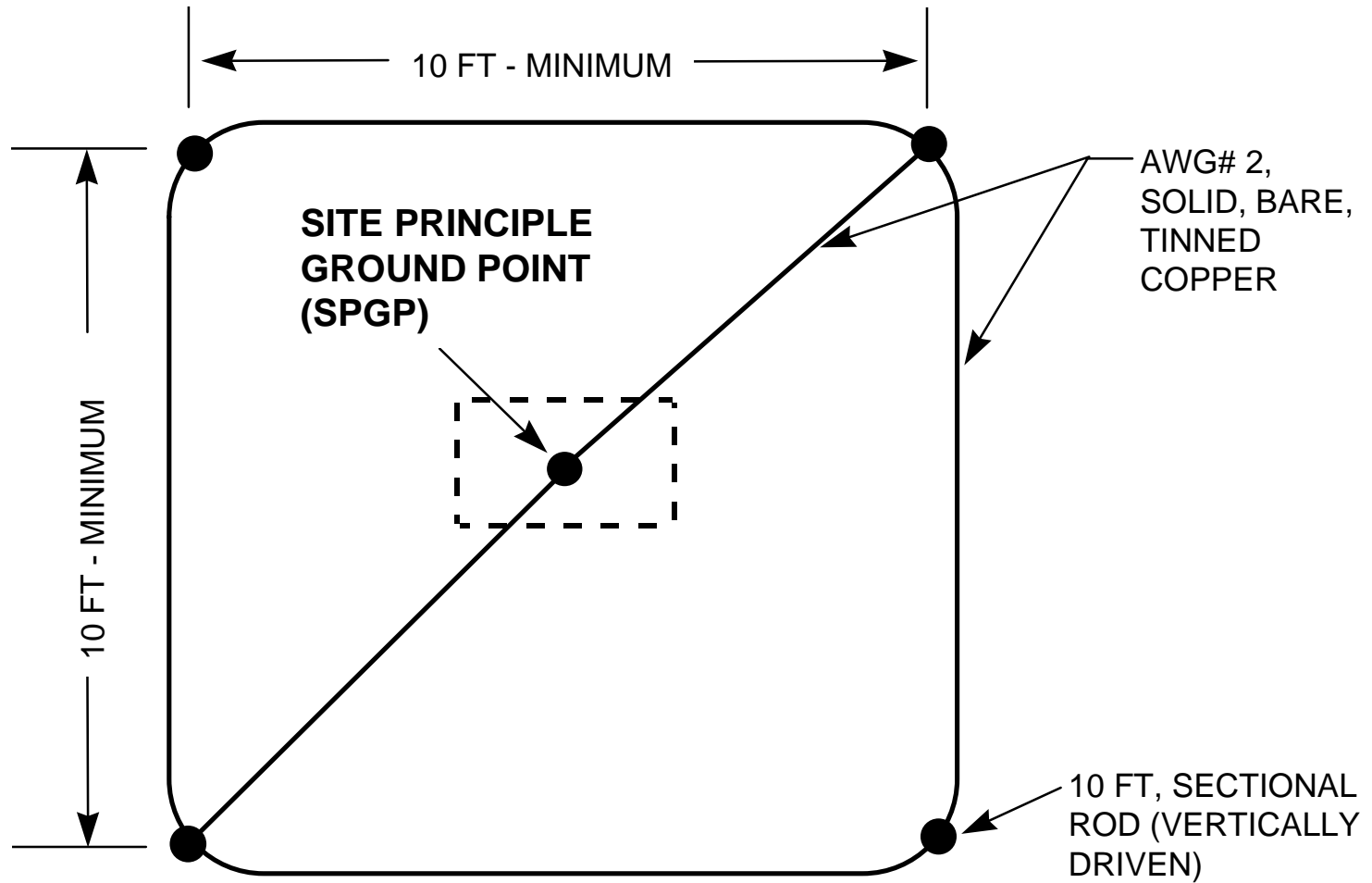

**MADE GROUND ELECTRODE - METHOD #4  
FIGURE F**





**TABLE A**

**Grounding Decision Model -- Remote Field Electronic Site**

| Design Approach  | Soil Resistivity (Meter - Ohm) | Resistance to Earth (Ohms) | CEH, Shelter Mount, Pad Mount, Pole Mount, and All Other REE Sites   |
|------------------|--------------------------------|----------------------------|--|
| <b>LOW</b>       | <b>&lt; 200</b>                | <b>&lt; 25</b>             | Method (1) - 4 Rods<br>Method (2) - Radial Wire Length = 15'/radial<br>Method (3) - 3 Rods (10')<br>Method (4) - 4 Rods                                  |
| <b>MEDIUM</b>    | <b>200 - 500</b>               | <b>&lt; 25</b>             | Method (1) - 10 Rods<br>Method (2) - Radial Wire Length = 40'/radial<br>Method (3) - 4 Rods (20')<br>Method (4) - 10 Rods (10') or 5 Rods (20')          |
| <b>HIGH</b>      | <b>500 - 1000</b>              | <b>&lt; 50</b>             | Method (1) - 10 Rods<br><b>Method (2)** - Radial Wire Length = 35'/radial</b><br>Method (3) - 4 Rods (20')<br>Method (4) - 10 Rods (10') or 5 Rods (20') |
| <b>VERY HIGH</b> | <b>1000 - 5000</b>             | <b>&lt; 50</b>             | Method (2) - Radial Wire Length = 200'/radial<br>***   |

